

## Teste a snodo SI PHS25-DURBAL - PHS25-DURBAL

<https://www.123cuscinetti.it/cuscinetti-supporti/teste-snodo/si/phs25-durbal>

**PHS25** 

**Description:** DIN ISO rod end K series. Sliding combination steel / heavy duty bronze.

**female thread:** lubrication required, according to DIN ISO 12240-4, series K

**Rod end body:** surface chromium plated

**Sliding combination:** steel / heavy duty bronze

**Inner ring:** bearing steel, hardened, ground and spherical surface chromium plated

**Outer ring:** heavy duty bronze with lubrication

**Lubrication:** lubrication required

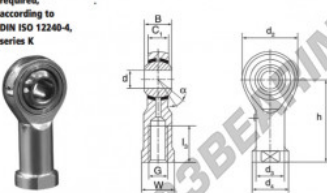

order number	right hand thread	left hand thread	d	G	B	C1	d2	d3	d4
PHS 25			25	M 24 x 2	31	22,00	60	33,5	42

type	measurement [mm]				load rating C <sub>0</sub> [kN]	weight [kg]
	l <sub>2</sub> min	W	h	α [°]		
PHS / PHSL 25	42	36	94	15	68,0	0,730

### CARATTERISTICHE DEL PRODOTTO

Marchio	DURBAL
N° Ean13	3663952495453
Diametro interno	25 mm
Diametro esterno	60 mm
Spessore	31 mm
Tipo	-
Peso	730 g
Il filo	-
Lubrificazione	-
Imballaggio	-

[contatto@123cuscinetti.it](mailto:contatto@123cuscinetti.it)

+33 3 59 36 04 90

CRT4 de Lesquin 60 Rue Du Haut De Sainghin 59273 Fretin FRANCE